



2019 San Diego County Fair Del Mar Fairgrounds Friday, May 31 – Thursday July 4, 2019



Closed the Mondays and Tuesdays in June

Application For Commercial Exhibit Space

Please review these instructions carefully as the application changes from year to year. Instructions for completing the application follow and additional information highlighting some of the rules and regulations are on page two. **INCOMPLETE APPLICATIONS MAY NOT BE CONSIDERED, AND MAY NOT BE RETURNED FOR COMPLETION AS WE APPROACH THE DEADLINE!!!** No incomplete applications will be evaluated if received or postmarked after March 6, 2019. So please, take a moment to familiarize yourself with this application packet.

INSTRUCTIONS FOR COMPLETING APPLICATION

1. A **\$25.00 Non Refundable Processing Fee (Check only and payable to 22nd DAA)** is required with each application. No space fee is due at this time – if a contract is issued, you will be billed.
2. Although it is not a first-come, first-served, selected applicants will be booked as space becomes available. The last date to submit an application is **March 6, 2019**.
3. **This application is neither an offer nor a guarantee of space.**
4. This is a two-sided application. All questions on both sides of the form must be answered completely. If you have any questions about the form, please call the **Concessions Office at (858) 792-4218**.
5. Be sure the information you give is accurate, as it will be the sole representation of your business to the Selection Committee. Additional information received *after* your application has been received by the Concessions Office **will not** be accepted!
6. The list of products you are requesting to sell/display/promote/giveaway must be specific. Words such as “accessories,” “etcetera,” “related products,” and other vague descriptions are not acceptable. If a contract is issued, it will be assigned on the basis of this list only, so please be thorough!
7. An informational brochure or picture(s) that visually describe each product must be included with your application. Please be certain to label all attachments with product name, company name, and price. (Please keep items to 8 1/2” x 11” or smaller)
8. **A photo or drawing of your proposed booth in operational form is required with each application.** (See booth specifications on back)
9. Samples of any hand-outs, brochures, catalogs, etc. must be attached and labeled with your name if you are planning to distribute them from your booth.
10. If a contract is issued, the location of your booth will be determined by management. In order to do so effectively, please **indicate your preference for an indoor or outdoor location**.
11. Microphone usage and Prize drawings to be held in your booth require prior approval from the Concessions Office. If you have checked off the Drawing Application or Microphone Application box on your application, this form will automatically be sent to you if a contract is issued. Microphone use is not guaranteed.
12. Be sure to list all persons (and their titles, if applicable) who have financial interest or ownership in this company. **Descriptions such as “none,” “self,” or “corporation” are not acceptable.**
13. Credentials (daily admission passes) will not be released to anyone not listed on your application as authorized to do so (this is not a list of all of your employees, simply a list of those who may check-in and pick up credentials at fair time).
14. Please indicate how many people (including yourself) work in the booth per day.
15. **MAKE SURE YOU SIGN THE APPLICATION WHERE INDICATED.**
16. Separate completed application from these instructions and mail application with attachments to:

Concessions Office, Del Mar Fairgrounds, P.O. Box 1088, Solana Beach, CA 92075



ADDITIONAL INFORMATION

If a contract is issued, you will receive a Licensee's Handbook detailing our rules, regulations, and operating policies. However, in our effort to assist you with our application process, we have highlighted the following pertinent information:

PRODUCT SALES/RESTRICTIONS

If a contract is issued, only those products listed on the contract may be sold, displayed, or given away. If you have requested to sell certain items on your application that are not listed on your contract, you *may not* sell those items. Items that will not be considered for sale are stun-guns, switchblades, brass-knuckles, high-powered water guns, rubber band toys/guns, products made from any endangered animal, pornographic or drug-related items, and stickers. Management reserves the right to determine whether an item is considered offensive or in poor taste, and to prohibit the sale/display of such an item. Watches and sunglasses must be listed separately.

SUBLEASING/BOOTH SHARING

Licensees are strictly prohibited from subleasing, assigning, or apportioning the whole or any part of their contracted space to any other business or individual.

EXCLUSIVE ITEMS

Balloons, inflatable toys, and glow-in-the-dark novelty items are covered under the 22nd D.A.A.'s novelty contract as exclusive items for sale by that contractor only. These items may not be sold or used as giveaway promotions by any other licensee or participant in the San Diego County Fair. Use of the San Diego County Fair logo is forbidden without prior written permission from the Concessions Office.

RECEIPTS

Sales slips, with contracted business name, address and telephone number **must** be furnished with each item sold to a patron. This is for the licensee's protection as well as that of management. Failure to do so will result in a violation that can affect future participation.

SIGNAGE

Each commercial exhibitor must post a sign, visible to the public, with the company name. (This name must match the contracted name.) These signs must be of a professional nature, no handmade signs will be allowed. Each exhibitor must post their policy for credit check, refunds, and exchanges so that it is visible to the patrons.

BOOTH SPECIFICATIONS

Display heights at rear of exhibits shall not exceed 8' in height. Side partitions and display material shall not exceed 48" in height, for a distance of five feet from the aisle. No part of the exhibit shall extend beyond the stepdown design or block the view to adjacent displays without prior approval. All above mentioned height requirements must be observed. We allow more flexibility in our height requirements and booth specifications in the O'Brien Pavilion, Infield, and Durante area. Aluminum poles used in construction of booth must be covered.

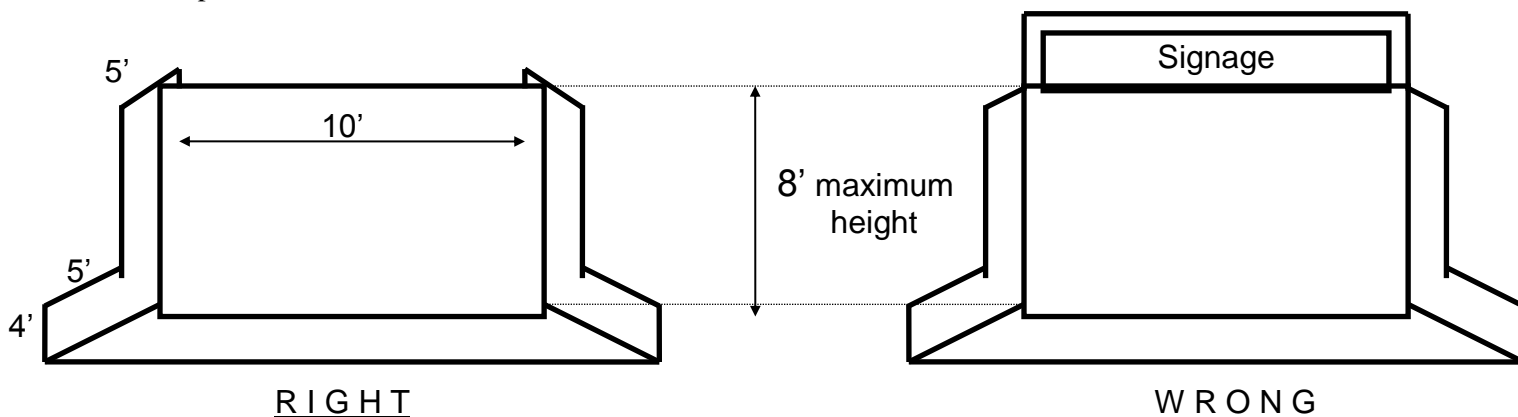

PLEASE NOTE THAT IF YOU ARE APPROVED FOR A CONTRACT YOUR BOOTH MUST COMPLY WITH THE STEP-DOWN DESIGN.



**22nd District Agricultural Association
2019 San Diego County Fair
Friday, May 31, 2019 through Thursday, July 4, 2019
Closed Mondays and Tuesdays in June**

Application for Commercial Exhibit Space

**A \$25.00 Non-Refundable Processing Fee (payable to 22nd DAA) is due with each application
Deadline: March 6, 2019**

OWNER/CONTACT NAME: _____
 BUSINESS NAME: _____
 ADDRESS: _____
 CITY/STATE: _____ ZIP: _____
 BUSINESS PHONE:(_____) _____ EMERGENCY/PAGER#: (_____) _____
 E-MAIL ADDRESS (If applicable): _____
 TAXPAYER'S ID #: _____ CALIF. SELLER'S PERMIT#: _____
 (attach copy to application)
 CONTRACTOR'S LIC # (If applicable & attach copy to application) : _____
 Have you ever participated in the San Diego County Fair? yes no If so, what year(s)? _____

PRODUCTS BEING REQUESTED FOR SALE, PROMOTION, GIVE-AWAY OR DISPLAY AND PRICES:

_____ PRICE: _____
 _____ PRICE: _____
 _____ PRICE: _____
 _____ PRICE: _____

If you need additional room, please attach a separate sheet.

- Please indicate here if you hand out edible samples to promote your product. (Prior approval is required.)
- Please indicate here if you are not selling during the fair and are only taking leads for future business. (Even if only taking leads, the State Board of Equalization requires you to file for a Seller's Permit).

SPACE SIZE

Space size requested: _____ Location Preference: indoor outdoor
 (for example 10x10, 10x20, 10x30)

Please be advised – management determines your location. Please refer to the Rate Sheet for pricing

******FOR OFFICE USE ONLY******

Location	Size	Corner	Total	Creds	Contract #
_____	_____	<input type="checkbox"/>	_____	_____	_____
_____	_____	<input type="checkbox"/>	_____	_____	_____
SCR (1)_____	(2)_____		(3)_____	(4)_____	RGT: SA PB BA
<input type="checkbox"/> Processing Fee Received _____					

REFERENCES REQUIRED:

Event Name Contact Name Year participated () Phone#

Event Name Contact Name Year participated () Phone#

PRIZE DRAWINGS / MICROPHONE APPLICATIONS

If a contract is awarded, please send me the following applications for permission to conduct a prize drawing or use a microphone in my booth:

- Prize Drawing Application Microphone Application
DRAWINGS AND MICROPHONES MAY NOT BE USED WITHOUT PRIOR APPROVAL.

INSURANCE REQUIREMENTS

Each Licensee must provide the District with proof of general liability insurance of no less than \$1,000,000; hazardous licensees--\$2,000,000. Please check the form of insurance you will provide during the fair:

- My own carrier* WFA Master List* Purchased through fairgrounds (approx \$135.00) (CFSA)

*Name of insured business must match business name on this application
Note: If you employ help you must provide a worker's comp. certificate

UTILITY REQUIREMENTS

Two 110-volt outlets are provided with each 10x10 booth. If your electrical needs are in excess of 110, please indicate:

Voltage: Phase: Amps:
(Additional fee may apply for electrical over and above 110)

Please indicate if your display requires: Running water Sewer

FINANCIAL INTEREST (see no. 12 of instructions)

Names are required of all persons with financial interest (ownership) in this business or organization (if a corporation, list corporate officers) NAMES:

CREDENTIAL AUTHORIZATION (see no. 13 of instructions)

List all persons authorized to pick up credentials:

How many people (including yourself) work in the booth per day?

I have read and understand the instructions and additional information attached. I understand that this form is an application for space only, and is neither a commitment by the applicant, nor an offer by the 22nd DAA to rent space. I understand that there is a \$25.00 Non Refundable Processing Fee (payable to 22nd DAA) due with each application. I certify that all information contained in this application to be true and accurate to the best of my knowledge.

SIGNATURE:

TITLE: DATE:

Concessions Office, Del Mar Fairgrounds, PO Box 1088, Solana Beach, CA 92075

